

2103,2104

METER RELAY

Instruction Manual

September 2013 Revised edition 2

Printed in Japan
2103A981-02 13-09H



HIOKI

HIOKI E. E. CORPORATION

Headquarters

81 Koizumi, Ueda, Nagano 386-1192, Japan
TEL +81-268-28-0562 FAX +81-268-28-0568

E-mail: os-com@hioki.co.jp URL http://www.hioki.com/
(International Sales and Marketing Department)

1307

For regional contact information, please go to our website at <http://www.hioki.com>.

The Declaration of Conformity for instruments that comply to CE mark requirements may be downloaded from the HIOKI website.

Specifications

(Accuracy guaranteed for one year at 23°C±5°C(73°F±9°F), 80%RH or less.)

Maximum scale value	According to the rating (to be specified at the time of ordering)
Setting system	HL type (upper/lower-limit setting), H type (upper-limit setting) L type (lower-limit setting) (electronic type, non-contact system)
Indicating-instrument section	
Class	2103: Class 2.5 2104: Class 1.5
Indicator shape and color	0.3φ pin, black
Indicator operating range	Within the scale (passing system)
Instrument characteristics	In accordance with JIS C1102
Setting indicator section	
Shape and color	Spear shape H indicator (upper-limit side): Red L indicator (lower-limit side): Green
Setting range	Within the scale for both H and L
Minimum H/L interval	Within 3% of the scale length
Setting accuracy	Within 1.5% of the maximum scale value (independent from the instrument section)
Dead-zone width	Within 0.5% of the scale length
Relay operation	
Control-status indication	H/L operation indication lamps
Delay time at power ON	Approx. 2 sec (standard model)
Response time (time constant)	Approx. 0.5 sec (standard model)
Contact structure	One transfer for both H and L
Relay ratings	
Current capacity	5 A (250 VAC, 30 VDC) (resistance load)
Insulation resistance	500 VDC, 1000 MΩ or higher (between the contact and coil)
Dielectric strength	5000 VAC for 1 min (between the contact and coil)
Electrical service life	Approx. 100,000 times (5 A)
Maximum rated voltage to ground	300 VAC/DC
Dielectric strength	3536VAC for 15 sec (between the instrument circuitry and the casing, between the power supply and the casing)
Power source	100 V/200 VAC (to be specified at the time of ordering) 50 Hz/60 Hz (Voltage fluctuations of ±10% from the rated supply voltage are taken into account.)
Maximum rated power	3 VA
Operating temperature and humidity	0 to 40°C (32 to 104°F) 80%RH or less (no condensation)
Storage temperature and humidity	-10 to 50°C (14 to 122°F) 80%RH or less (no condensation)
Location for use	Indoors, altitude up to 2000 m (6562-ft.)
Dimensions	2103 Approx.84W × 72H × 117.6D(rear section), 25.9(front section) D mm Approx.3.31"W × 2.83"H × 4.63"D(rear section),1.02"D(front section) 2104 Approx.104.4W × 88.4H × 117.6(rear section),25.9(front section) D mm Approx.4.11"W × 3.48"H × 4.63"D(rear section),1.02"D(front section)
Mass	(2103) Approx.480 g, Approx.16.9 oz. (2104) Approx.460 g, Approx.16.2 oz.
Accessories	Instruction Manual 1 U-shaped mounting hardware (2103)..... 1 mounting screws (2103) 2 nuts (2104) 4 spring washer (2104)..... 4

Safety Notes

This manual contains information and warnings essential for safe operation of the product and for maintaining it in safe operating condition. Before using it, be sure to carefully read the following safety precautions.

WARNING

- **Mishandling this product during use could result in injury or death, as well as damage to the product. Be certain that you understand the instructions and precautions in the manual before use. We disclaim any responsibility for accidents or injuries not resulting directly from product defects.**
- **HIOKI is not responsible for problems associated with malfunctions of the 2103 and 2104 caused by other systems and devices that use the 2103 and 2104 Meter Relay.**

Safety Symbols

	In the manual, the symbol indicates particularly important information that the user should read before using the product. The symbol printed on the product indicates that the user should refer to a corresponding topic in the manual (marked with the symbol) before using the relevant function.
	Indicates AC (Alternating Current).
	Indicates DC (Direct Current).

The following symbols in this manual indicate the relative importance of cautions and warnings.

	Indicates that incorrect operation presents an extreme hazard that could result in serious injury or death to the user.
	Indicates that incorrect operation presents a significant hazard that could result in serious injury or death to the user.

Notes on Use

Follow these precautions to ensure safe operation and to obtain the full benefits of the various functions.

WARNING

- **Do not allow the product to get wet, and do not take measurements with wet hands. This may cause an electric shock.**
- **Before turning the product on, make sure the supply voltage matches that indicated on the its power connector. Connection to an improper supply voltage may damage the product and present an electrical hazard.**
- **When the product is connected, do not touch the power-supply terminals or input terminals. Touching them may cause electric shock or injury since live lead sections are exposed.**
- **To avoid electrical accidents, confirm that all connections are secure. The increased resistance of loose connections can lead to overheating and fire.**
- **Do not supply power exceeding the ratings. A nonconforming power supply may cause damage or short-circuiting in the product.**
- **To prevent the risk of electric shock and other accidents, the product must be mounted on a panel in such a way that the rear panel of the product cannot be touched. Never use the product on its own.**
- **When mounting the product on a panel and when wiring the terminals, wear suitable protection as prescribed by labor safety regulations, such as electrical safety gloves, electrical safety boots, and a safety hat to prevent the risk of electric shock.**
- **To avoid electric shock, do not remove the product's case. The internal components of the product carry high voltages and may become very hot during operation.**
- **The signal input circuit and meter circuit of the product are not insulated. Should the meter section or dial be damaged, electric shock may result. If the product becomes damaged, discontinue its use immediately and contact your dealer or Hioki representative.**

CAUTION

- This product is designed for use indoors. It can be operated at temperatures between 0 and 40°C without degrading safety.
- This product is not designed to be entirely water- or dust-proof. Do not use it in an especially dusty environment, nor where it might be splashed with liquid. This may cause damage.
- Do not store or use the product where it could be exposed to direct sunlight, high temperature or humidity, or condensation. Under such conditions, the product may be damaged and insulation may deteriorate so that it no longer meets specifications.
- Be careful to avoid connecting the supply voltage improperly. Doing so may damage the instrument's internal circuitry.
- To avoid breaking the cables, do not bend or pull them.
- Do not apply excess force to the meter glass surface. Pressing on the meter glass surface may break the glass and cause injury. If the glass is altered, the setting indicator may become deformed and interfere with the meter, thus preventing proper operation.
- Set the H/L dial within the meter operating range. Forcibly turning the dial outside the operating range and beyond the stopper position may cause internal setting deviation, damage, or malfunction.
- For HL type, H indicator should be used on the right side of L indicator. Forcibly moving indicators while they are in contact may cause damage.
- Do not use the product in a location where it will be exposed to dust, organic gas, or sulfuric gas, as they may cause relay-contact problems.
- Note that vibration and shock may cause faulty contact between the relay and socket.

Maintenance and Service

WARNING

Never modify the product. Only Hioki service engineers should disassemble or repair the product. Failure to observe these precautions may result in fire, electric shock, or injury.

Periodic Inspection

- Change the H (L) indicator setting occasionally to confirm proper operation of the meter relay. For example, move the H setting indicator to a position lower than the normal value indicated by the meter, and confirm that the H relay operates.
- Check the upper/lower-limit setting dials for damage.
- Confirm that the indicator of the instrument is at the zero position when there is no input. If the indicator deviates from the zero position, make an adjustment using the zero-adjustment dial.
- Clean the meter glass surface with a dry cloth regularly to ensure clear visibility of the meter indicator at all times.
- If the product is used in an application that involves frequent relay operations, replace the relay regularly. In such an application, the contact resistance may increase and prevent proper operation. (The electrical service life at the rated load is approximately 100,000 times.)The relay cannot be replaced by the user. Contact your dealer or Hioki representative.

Maintenance

To clean the product, wipe it gently with a soft cloth moistened with water or mild detergent. Never use solvents such as benzene, alcohol, acetone, ether, ketones, thinners or gasoline, as they can deform and discolor the case.

Service

If the product seems to be malfunctioning, contact your dealer or Hioki representative. Pack the product so that it will not sustain damage during shipping, and include a description of existing damage. We do not take any responsibility for damage incurred during shipping.

Overview

This product is an electronic non-contact meter relay. Unlike conventional oscillator or photoelectric-type products, which detect the operating point based on the location of the indicator, the Hioki product uses an input for direct relay operation. This eliminates erroneous operations caused by indicator overshoots or friction. The product is also equipped with easy-to-see LED lamps for display of the operating status.

Inspection

When you receive the product, inspect it carefully to ensure that no damage occurred during shipping. If damage is evident, or if it fails to operate according to the specifications, contact your dealer or Hioki representative.

Preliminary Checks

Before using the product, make sure to inspect it carefully, referring as needed to the list of points for periodic inspection, to verify that it operates properly and to ensure that no damage occurred during shipping or storage. If you find any damage, contact your dealer or Hioki representative.

Processing the Panel

By referring to the dimensions shown in the diagram below, process the panel. (The panel thickness should be between 1.5 mm and 5 mm. For the 2104, holes must be drilled at four locations.)

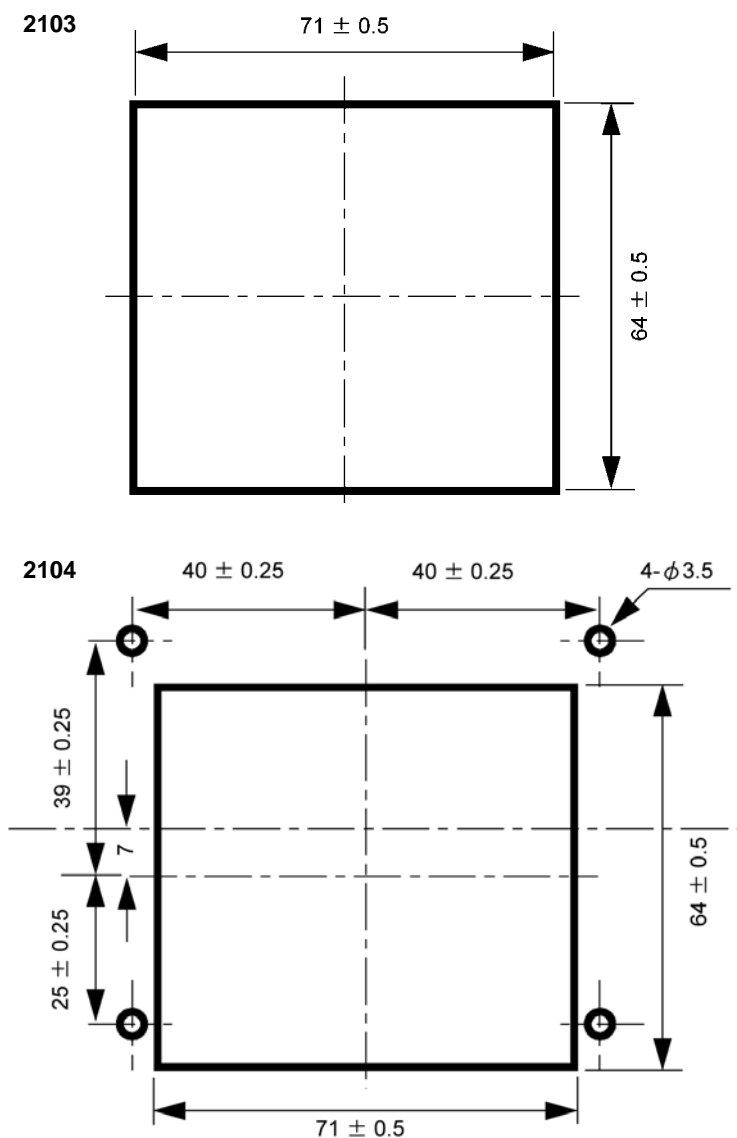

Mounting on the Panel

2103

1. Remove the U-shaped mounting hardware.
2. Mount the product on the front of the panel.
3. Mount the panel on the rear of the meter, and clamp the panel using the U-shaped mounting hardware. Be sure to use the supplied screws to securely tighten the U-shaped fixture. Use a force of 0.2 to 0.3 N•m torques.

2104

1. Mount the product on the front of the panel.
2. Use the supplied nuts and spring washer to clamp the product and panel.

Parts Names

Front Panel

2103

(HL Type)

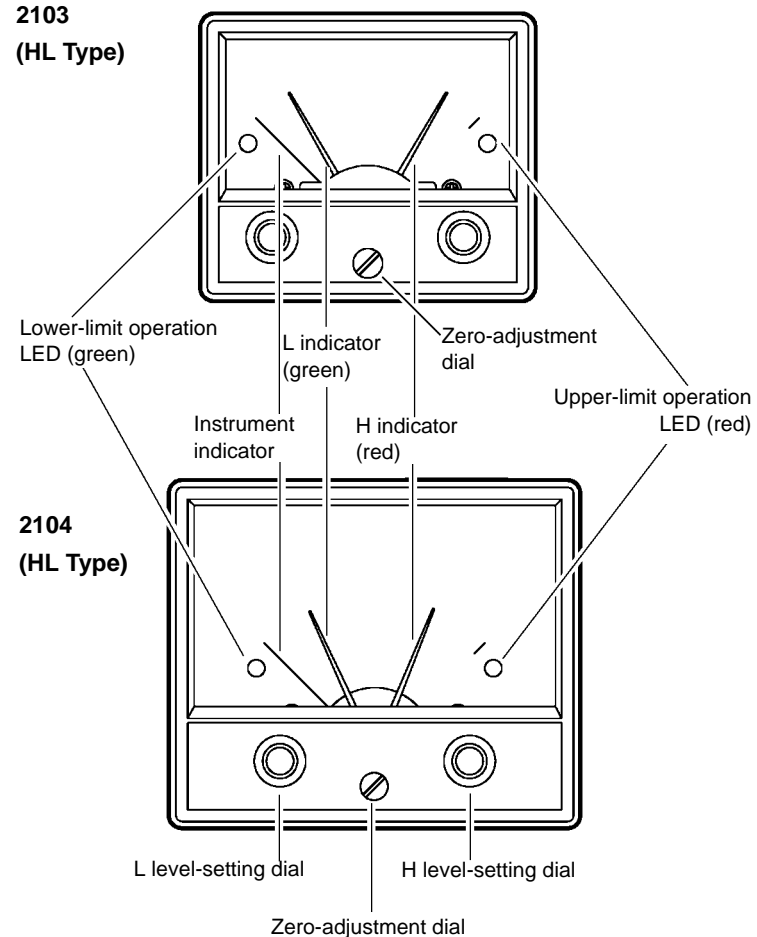

(The H type and the L type have only one operation LED on either side and only one level-setting dial on the right.)

- Meter (scale plate) Scale specified by the customer at time of purchase
- H level-setting dial Used to set the upper-limit level
- L level-setting dial Used to set the lower-limit level
- Upper-limit operation LED (red) When the meter indicator moves past the location of the H indicator, the H relay operates and the LED lights up.
- Lower-limit operation LED (green) When the meter indicator falls past the location of the L indicator, the L relay operates and the LED lights up.
- Zero-adjustment dial Used for zero-point adjustment under no-input conditions

CAUTION

If the H and L setting indicators contact with each other, do not forcibly turn the setting dial; otherwise, the setting indicators will be damaged.

Rear Panel

2103

(HL Type)

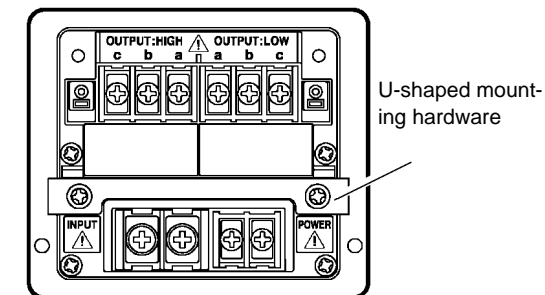

2104

(HL Type)

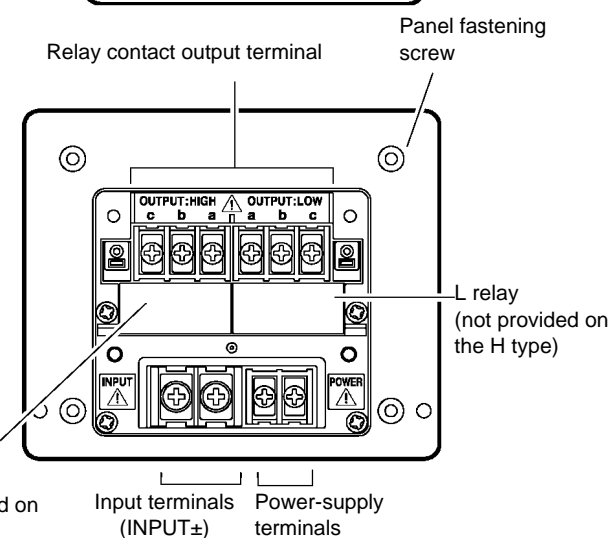

H relay Operates when the red LED turns on (continuity between a and c)
L relay Operates when the green LED turns on (continuity between a and c)

Connections to Terminals

Signal input

- Check the positive and negative polarities when connecting a DC input.
- When the product is connected in series to a load in a power line, connect the product to the ground potential (lower potential) side whenever possible.
- In the case of DC, if the maximum scale value exceeds 20 A, use a shunt. If it exceeds 300 V, use a multiplier.
- In the case of AC, if the maximum scale value exceeds 5 A, use a CT. If it exceeds 300 V, use a multiplier.
- When an extremely small DC signal is input, use a shielded cable for noise prevention.
- Make sure the terminal screws are fastened tight. Loose terminal screws may cause malfunctions or accidents. (at tightening torque of 1.2 N•m)

Relay-contact output

- The diagram on the label located on the top surface of the product indicates the contact status in the non-operating condition. When the relay operates, continuity is established between a and c. Design a sequence accordingly.
- The relay contact capacity is 5 A (resistance load). When an induction load is connected, reduce the load to prevent it from shortening the service life of the contact.
- Make sure the terminal screws are fastened tight. Loose terminal screws may cause malfunctions or accidents. (at tightening torque of 0.5 N•m)

Power-supply connection

- Connect a power supply conforming to specifications.
- The product is equipped with a delay function to prevent operation of the relay for approximately two seconds after the power is turned on. This allows the use of power output from the power-supply unit of the controlled equipment.
- Select a power cable of sufficient current-carrying capacity and withstand voltage, considering the power consumption and supply voltage. (Power consumption: 3 VA)

- Make sure the terminal screws are fastened tight. Loose terminal screws may cause malfunctions or accidents. (at tightening torque of 0.5 N•m)
- Excessive noise in the power source may cause malfunctions. Make sure to take any necessary precautions, such as attaching a ferrite clamp to the power cord.

CAUTION

- For safety, install a power cutoff switch or a circuit breaker near this device.
- Be careful not to connect wires to the power-supply terminals improperly. Doing so may damage the instrument's internal circuitry.

2103, 2104 (Rear view)

Terminal Arrangement (When power is off)

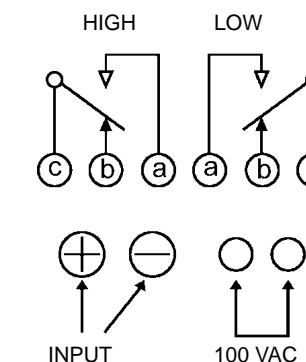

Connection example

Prevention of overload operation of the motor

Meter relay used: H type AC ammeter equipped with starting-current protection

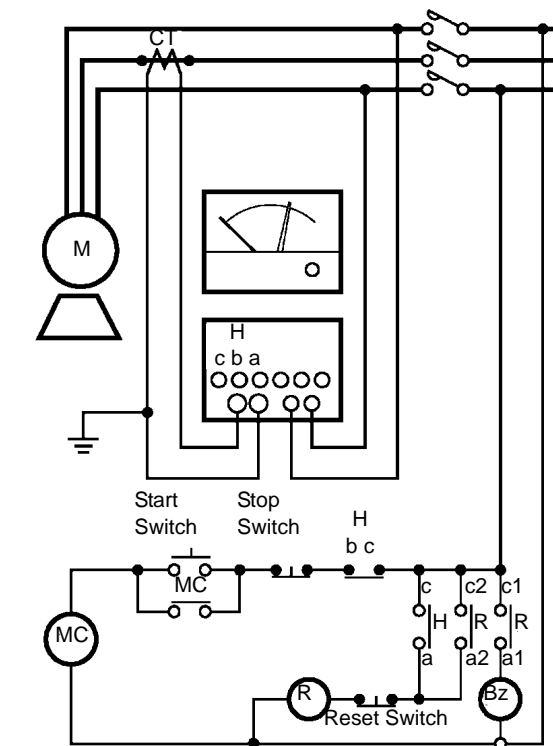

CAUTION

- After the terminals are connected, check to confirm that the signal lines do not come in contact with adjacent power cables.
- When using CT, be sure to ground the signal line for connection to the -terminal of the measuring instrument in order to ensure safe input.